



ACTIVE AIR 4

ALTERNATING MATTRESS OVERLAY

USER MANUAL



PTM639100

**Active Air 4 Alternating
Mattress Overlay - Single**

TABLE OF CONTENTS

1. Introduction	4
2. Safety Precautions	6
3. Product Safeguards	7
4. Product Overview	8
5. Assembly & Setup	9
6. Operation	12
7. Product Specifications	19
8. Cleaning	20
9. Maintenance & Storage	21
10. Troubleshooting	22
11. Warranty & Service	23
12. Service Log Book	24

Thank you for choosing this Aspire Active Air 4 Alternating Mattress Overlay.

This overlay has been specifically designed to offer safety, comfort and support.

It is important that you read this user manual carefully before using your new mattress overlay.

SYMBOLS USED IN THIS MANUAL

The symbols below are used throughout this user manual and on the product to identify warnings and important information. It is very important for you to read them and understand them completely.



WARNING! Indicates a potentially hazardous condition/situation. Failure to follow designated procedures can cause either personal injury, component damage or malfunction. On the product, this icon is represented as a black symbol on a white triangle with a black border.



ALWAYS! These actions should be performed as specified. Failure to perform mandatory actions can cause personal injury and/or equipment damage. On the product, this icon is represented as a white infinity symbol on a black dot with a white border.



DO NOT! These actions are prohibited. These actions should not be performed at any time or in any circumstances. Performing a prohibited action can cause personal injury and/or equipment damage. On the product, this icon is represented as a white symbol with a black circle and black slash.



Range is 30-135kg

PATIENT WEIGHT RANGE. This represents the range within which the mattress overlay provides effective pressure redistribution outcomes. Patient weight should NOT fall outside this range at any time as this may void warranty and/or produce ineffective patient support outcomes.

1. INTRODUCTION

The Aspire Active Air 4 is an electrically operated Alternating Mattress Overlay offering a suite of features for a patient at medium to high risk of pressure injury. Ease of use, functionality, serviceability and cleaning practicality are key features of the dynamic mattress overlay system.

Clinical Applications and Area of Use

This Alternating Mattress Overlay is appropriate for adult patient care and should only be used under the instruction of a carer or health professional where concerns exist around patient safe use.

Intended Use

The Aspire Lifecomfort Active Air 4 Alternating Mattress Overlay is intended to help and reduce the incidence of pressure ulcers while optimising patient comfort. The Active Air 4 may be used in a variety of environments included, but not limited to in home care, aged care and hospital.

Product Description

The Aspire Lifecomfort Active Air 4 is an Alternating Mattress Overlay System used in the prevention and relief for patients with, or vulnerable to, pressure ulcers. The Active Air 4 offers patients a comfortable and relaxing support surface by using the established principles of alternating therapy, which can both prevent skin breakdown and enhance healing.

The mattress overlay pump features a semi-digital pressure adjustment function, mode selections and audiovisual alarms.

The overlay features a multi-stretch PU coated fabric cover (with high MVTR) along with 16 x alternating air cells, 3 x static head cells and a rapid release twist CPR Valve for use in the event of a CPR emergency.

Key Features

- Patient weight range of this mattress overlay is 30-135kg, this should not be exceeded at any time
- **AutoLock** – The control panel automatically locks if not touched for 30 seconds preventing accidental changes to modes and settings
- **Multi-stretch, Vapour Permeable Cover** – Easy to clean cover is multi-stretch and breathable, reducing friction and shear whilst optimising skin microclimate
- **Welded Seams & Zip Protection** – Prevents fluid and bacterial ingress into the system, facilitating stringent infection control measures
- **Rapid Release CPR** – Allows quick deflation for cardio-pulmonary resuscitation in emergency situations
- **Audible & Visual Alarms** – Staff are immediately alerted if a problem occurs, maximising peace of mind and reducing patient risk
- **Low Noise Pump** – Semi-digital control unit features innovative pump technology to reduce vibration and facilitate improved patient sleep quality
- **Comfort Control Dial** – Allows nursing staff to adjust pressures to suit the patients pressure care and comfort requirements
- **Variable Cycle Times** – A choice of 10,15 or 20 minute cycles to meet the needs and comfort requirements for a wide range of patients
- **Simple Cell Connections** – O-ring connections make maintenance hassle and tool free
- **Hassle Free Pump Maintenance** – Modular pump design ensures pumps can be fixed and returned to service quickly with minimal downtime
- **Power Cord Protection** – L shaped connection coupled with the protector function, significantly reduce the risk of the power cord becoming loose and getting damaged
- **Cable Management** – Cords are retained within the overlay so the risk of tripping and cord pinching is eliminated
- If placed in static mode, after 20 minutes the system will fall back to alternating mode ensuring maximum patient protection and pressure management
- Cell retention band prevents the inadvertent movement or separation of the cells that could lead to friction and shear

2. SAFETY PRECAUTIONS

This user manual outlines the intended use of the Aspire Active Air 4 Alternating Mattress Overlay, the intended use constitutes how to achieve maximum pressure redistribution whilst maximising safety and efficiency for care staff and patients alike.

It is **IMPORTANT** that this user manual is read in its entirety prior to operating the Overlay. This manual is designed to ensure that users are equipped with the information required to competently and responsibly operate the overlay and pump.

It is recommended that the user manual be kept in an easily accessible place for quick reference. If required, Aidacare product specialists can provide additional training.

All **WARNINGS** and **CAUTIONS** within this manual should be strictly adhered to. Failure to do so could result in harm to the patient or operator.

CAUTIONS highlighted throughout this manual identify possible hazards in procedures or conditions, which if not followed correctly could result in equipment damage, or failure.





WARNINGS highlighted throughout this manual identify possible hazards in procedures or conditions which if not followed correctly could result in serious injury, or fatality.

General

- Electrical equipment can be hazardous if used incorrectly
- Residual current devices (RCD) are not supplied with Active Air 4 Overlays. Please consult with your Biomedical Engineer/advisor concerning RCD requirements
- The clinically qualified person responsible should consider the age, size and condition of the patient before using the Alternating Mattress Overlay
- The maximum safe working load of the Active Air 4 is 135kg with a safe patient range of 30-135kg
- This overlay is to be used only on top of a mattress support surface. This is **NOT** a mattress replacement system so sufficient support such as a mattress or pressure safety underlay must be used at all times

3. PRODUCT SAFEGUARDS

SAFEGUARD	DESCRIPTION
 <p>WARNING! To reduce the risk of electrocution</p>	<ol style="list-style-type: none"> 1. Occupants should not operate the product at any time. Always ensure the pump is unplugged when not in use. 2. Do not disassemble the pump at any time. 3. Do not place or store the pump close to water or any other liquid. 4. Do not submerge the pump in water or any other liquid. 5. Do not make contact with the pump if it has come into contact with water or any other liquid. Switch off the power outlet and then unplug immediately.
 <p>WARNING! To reduce the risk of burn, electrocution, fire or injury to the patient</p>	<ol style="list-style-type: none"> 1. The mattress must be operated by connecting it to the pump. Always ensure it is not turned off or unplugged whilst in use. 2. Always ensure warning labels are adhered and that voltage is correct, approved power cords are used and that Children & Animals do not come into contact with packaging materials that could cause suffocation. 3. Equipment is not suitable to be used in the presence of a flammable anaesthetic mixture with air, oxygen or nitrous oxide. 4. Keep away from sharp objects. 5. Close supervision is necessary when this product is used by, on, or near children or adults with disabilities. 6. Use this product only for its intended use as described in the user manual. Do not use attachments not recommended by Aidacare 7. Do not operate this product if the pump has a damaged power cord or plug, not working properly, has been dropped or damaged or dropped/submerged into water or another liquid. If this occurs, contact your Aspire dealer immediately for a product inspection. 8. Keep the power cord away from hot surfaces. 9. Do not block the air valves/tubes/openings by placing on a soft surface such as a bed or couch. Keep all valves/tubes/openings responsible for air flow, clear of all lint, hair and other particles. 10. Do not insert any object into the air valves/tubes/openings. 11. Avoid dropping pump and do NOT mount any heavy objects on top of it. 12. Place the power cord and air hoses at the occupant's foot area to avoid risks of strangulation. 13. Avoid electromagnetic interference by ensuring that electro-magnetic or RF generated equipment is kept away from the occupant. 14. Over the course of operation, the pump will generate a small amount of heat. Do not maintain skin contact with pump for more than 1 minute at a time. Never cover the pump when it is in use, ensure air flow to pump is free at all times. 15. During a power outage or loss (even if only temporary) the pump will stop and power failure alarm will sound for up to 20 seconds. The pump will return to normal operation once the power supply is resumed. 16. Connect this product to a properly grounded outlet only. 17. Avoid the risk of electrocution by grounding the ground pin with grounding power outlet. 18. The EMC specification is compliant with all regulations and requirements. For power leads with a ground pin, the connection with properly grounded power outlets will suppress the EMC effect. The pump will work correctly for power leads that are not grounded.

4. PRODUCT OVERVIEW

The Aspire Active Air 4 Dynamic Mattress Overlay has been designed for the aged care and hospital environment. Please take the time to familiarise yourself with the key components shown below:

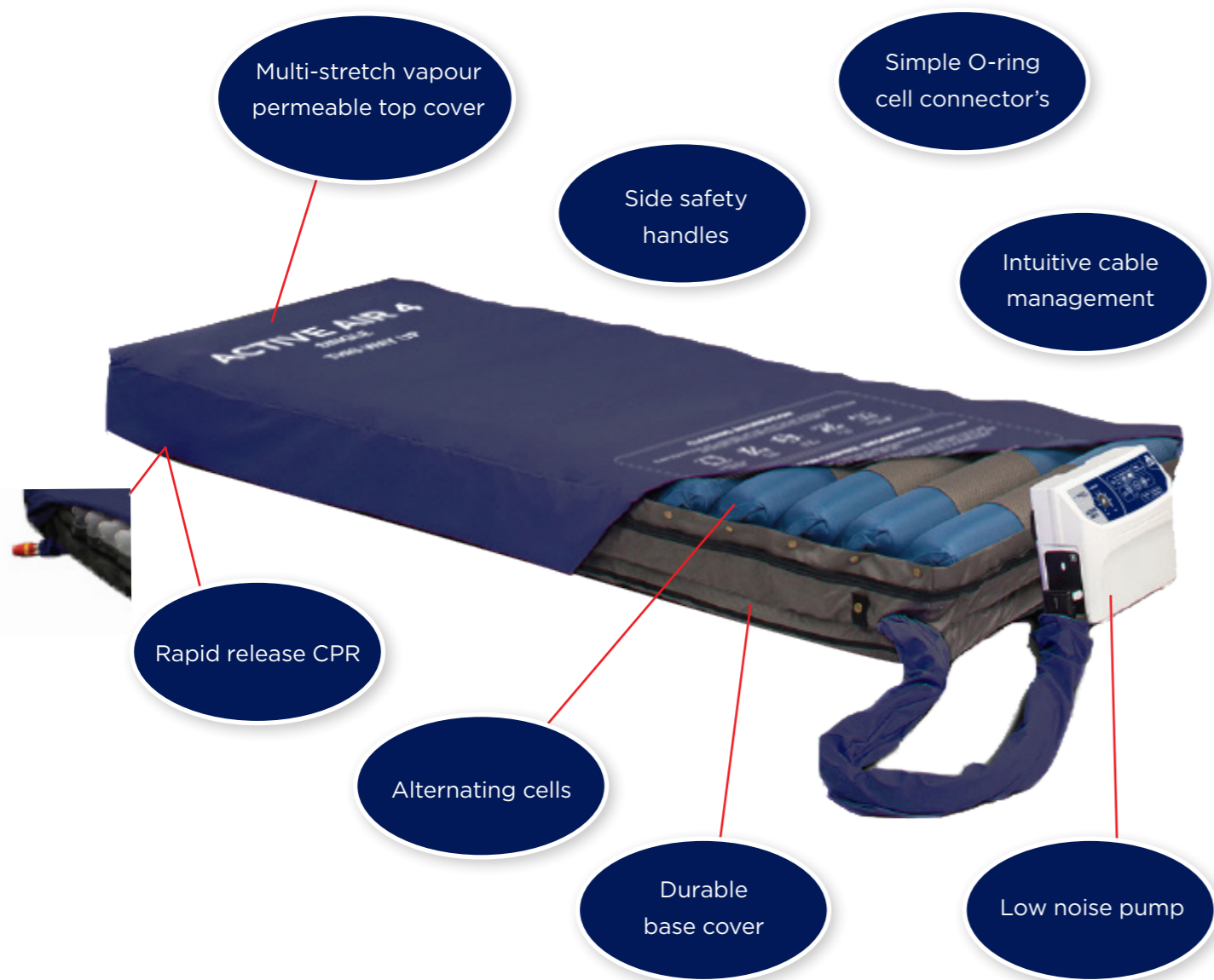

5. ASSEMBLY & SETUP

Box Contains:

1. Semi-digital Mattress Pump
2. Mains Power Cable
3. 4 inch Mattress Overlay
4. Transport Carry Bag
5. User manual



When opening the carton, ensure it is done in a safe and careful manner. **DO NOT USE** a box cutter or sharp implement as this may damage the product.

1. Place the 4 inch Mattress Overlay on the support surface, ensuring that there is a foam mattress or pressure safety underlay underneath. Ensure the air pump hose is towards the **FOOT END** of the bed so it lines up with the pump

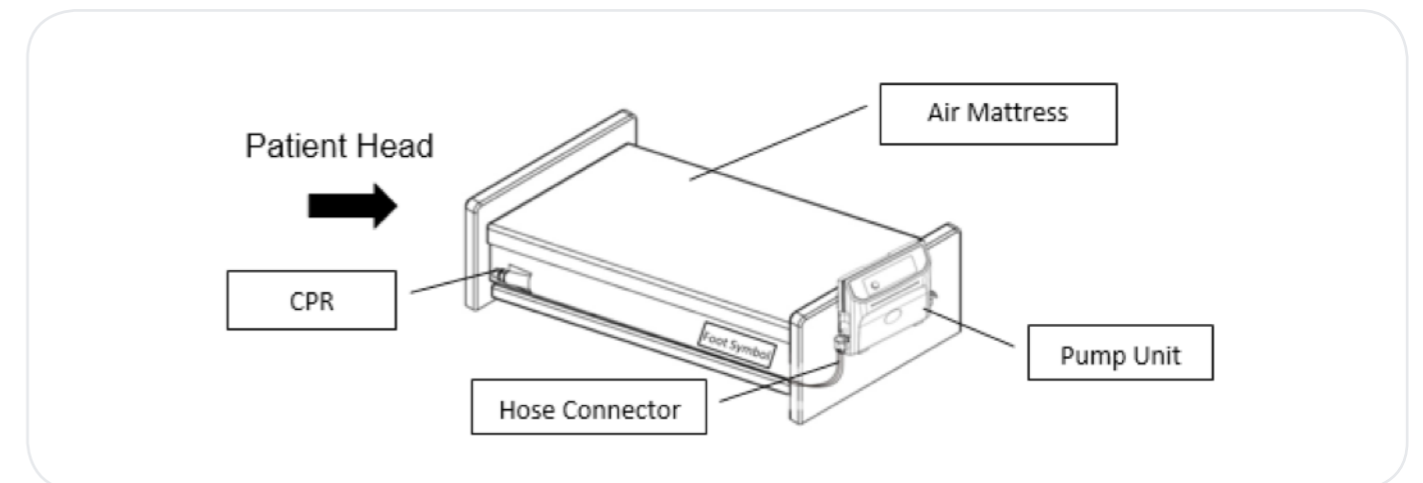

2. Secure the overlay onto the mattress or pressure safety underlay by using the elastic straps

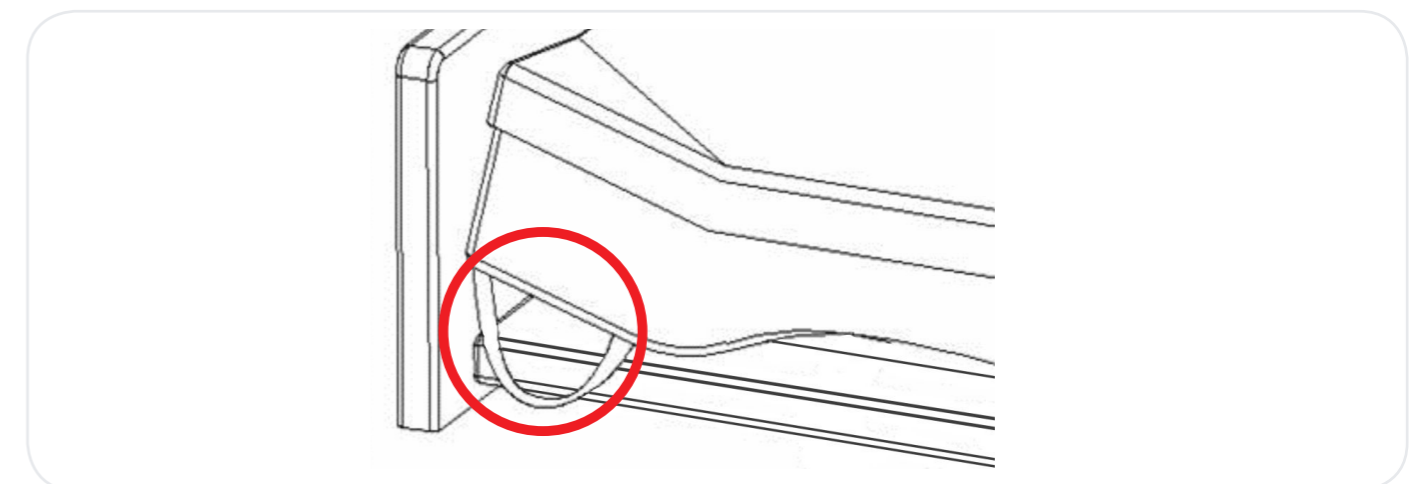

3. Ensure the CPR valve is at CLOSE position

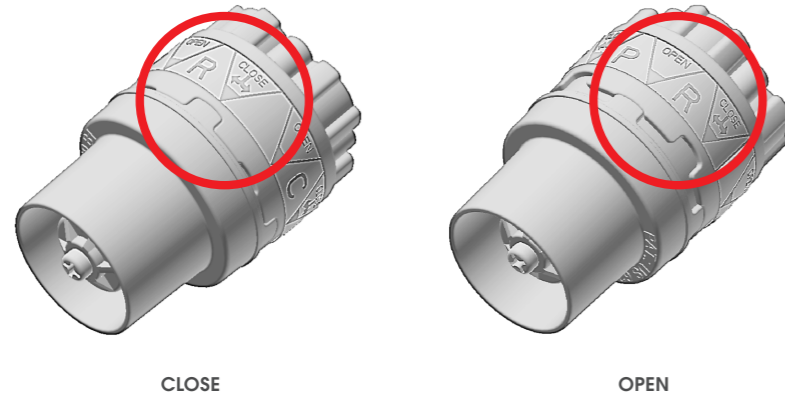

4. Position the pump on the **FOOT END** of the bed end. The spring hanger bracket assembly will self-adjust onto the footboard to secure it in place

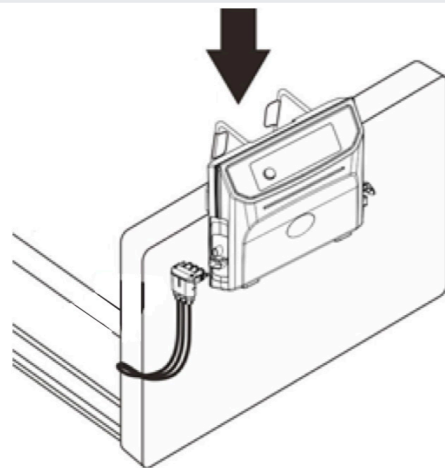

5. Remove the plastic protector cap from the end of the air hose

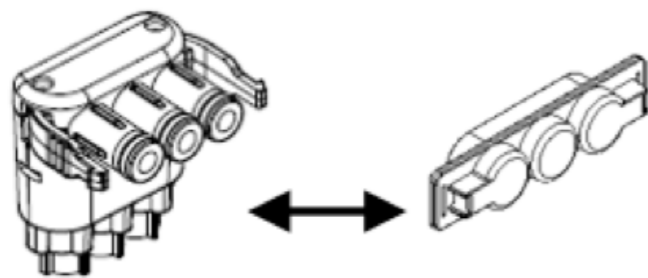

6. Firmly push the hose connector into the side of the pump until a notable **'click'** sound is heard

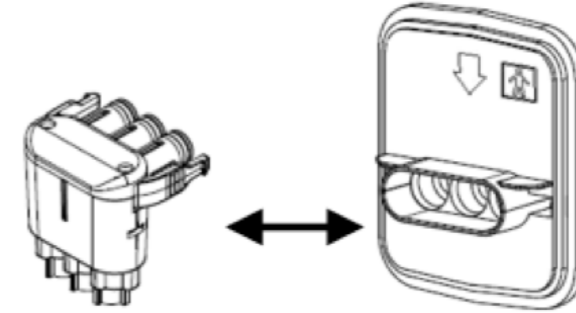

7. Connect the mains power cable to the pump ensuring that the power switch remains switched OFF

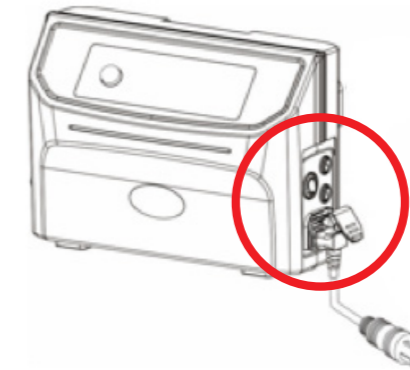

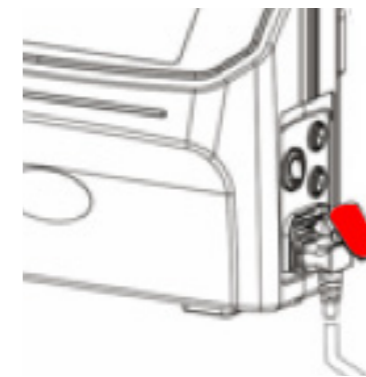

8. Press down in the L shaper power cord protector to secure the power cord in place



9. Plug the mains power cable into the electrical power socket

10. Set mode suitable for patient, (Refer to **GENERAL OPERATION** for further details on how to adjust the mattress overlay)

 **WARNING! DO NOT** place the pump unit in an area where the power cord can become pinched or stuck

 **WARNING!** The semi digital pump is only to be used with the Aspire Active Air 4 and not any other system

6. OPERATION

Aspire Active Air 4 Alternating Mattress Overlays are powered by a semi-digital pump which can be controlled with the adjustment control panel.

Various modes can be set on the semi-digital pump to ensure maximum comfort and safety for the patient.

Adjustment Control Panel Operation

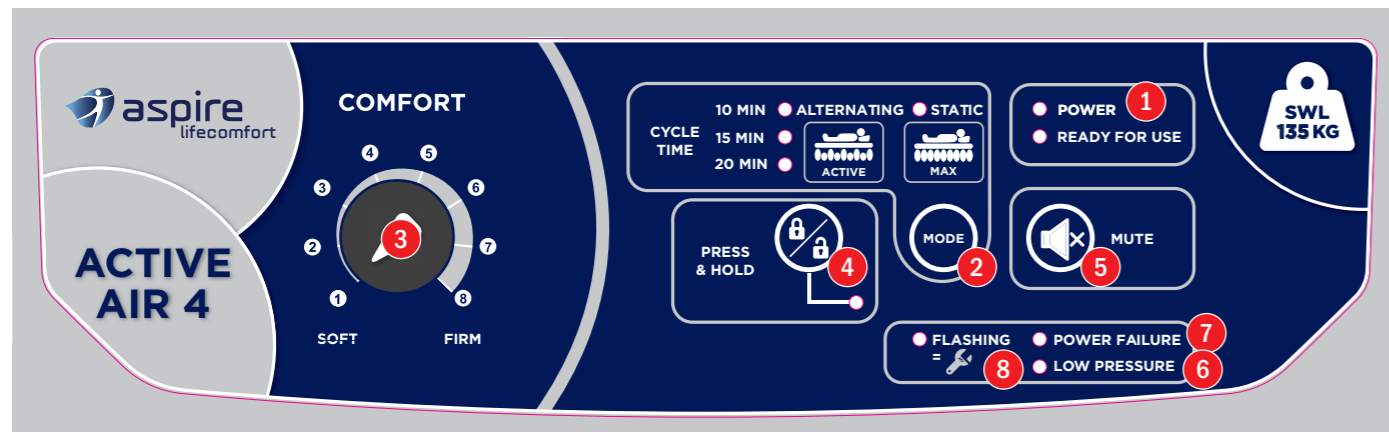

- 1 Power On/Ready for Use
- 2 Pressure Mode Adjustment - Static vs Alternating
- 3 Comfort (Pressure) Adjustment
- 4 Function Lock Out
- 5 Mute
- 6 Low Pressure
- 7 Power Failure
- 8 Service Required

Power On/Ready For Use

The power switch for the pump is located on the side of the pump.

1. Press the power switch up to turn the pump power on. All lights will illuminate for 2 seconds whilst a beep will follow confirming power to the unit is now connected to the power
2. The **'Power'** LED light will become illuminated and the pump will inflate to normal pressure, which is signified with the **'Ready for use'** LED light becomes illuminated

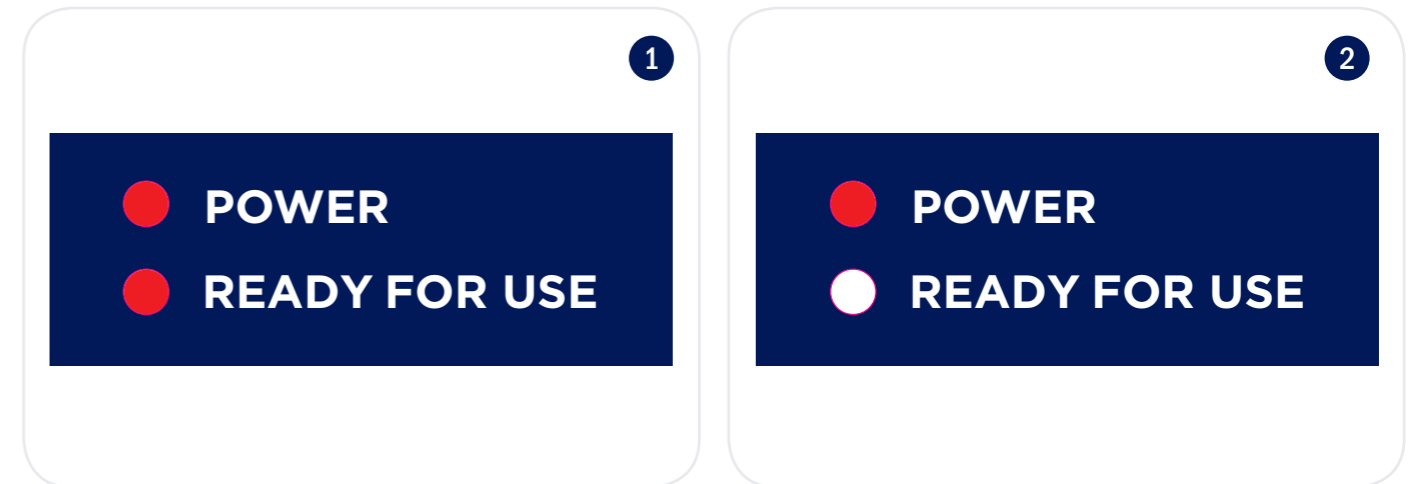

Pressure Mode Adjustment - Static vs Alternating

Static Mode

1. Press the mode button until the **'Static'** LED light is illuminated
2. Static mode will automatically fall back to **'Alternating'** mode after 20 minutes

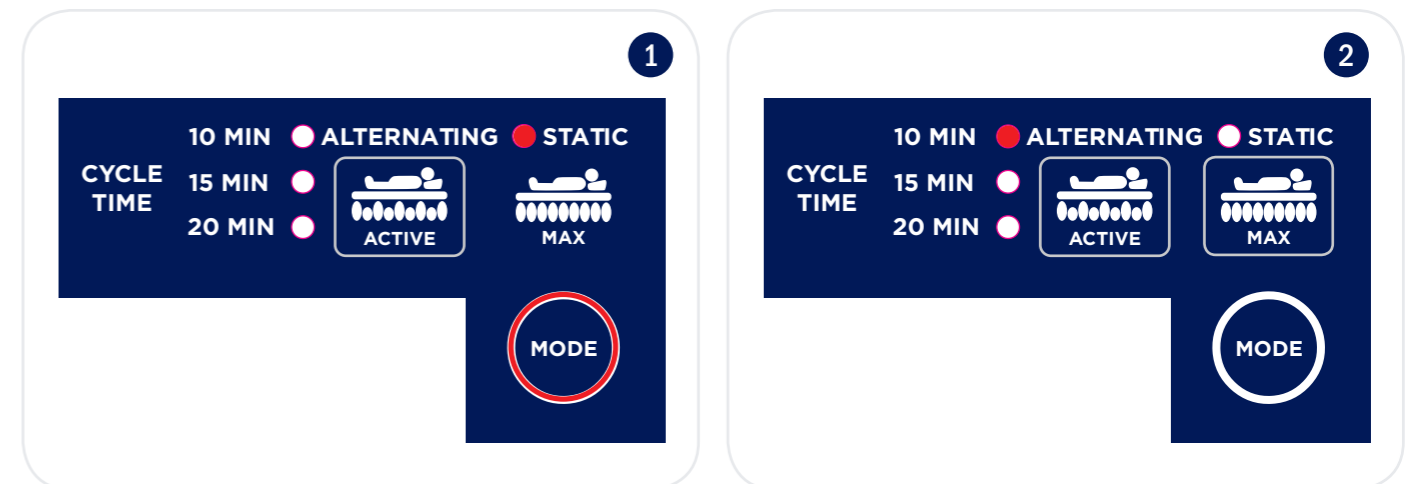

Alternating Mode

1. Press the mode button until the 'Alternating' LED light is illuminated
2. Toggle the alternating cycle times (10, 15 or 20 minutes) by pressing the mode button

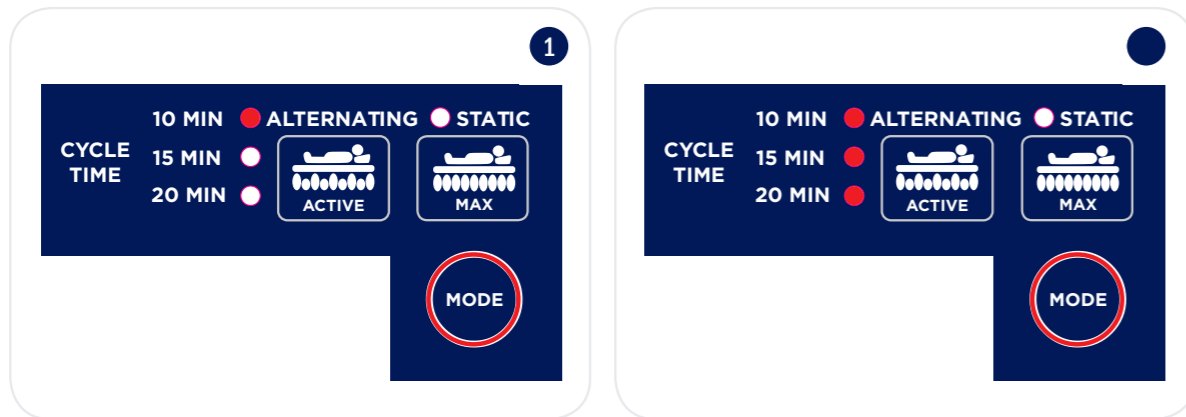

Comfort (Pressure) Adjustment

The easy turn dial ensures comfort can be easily adjusted to suit the patient.

1. Turn the comfort dial to the right to increase the pressure
2. Turn the comfort dial to the left to decrease the pressure

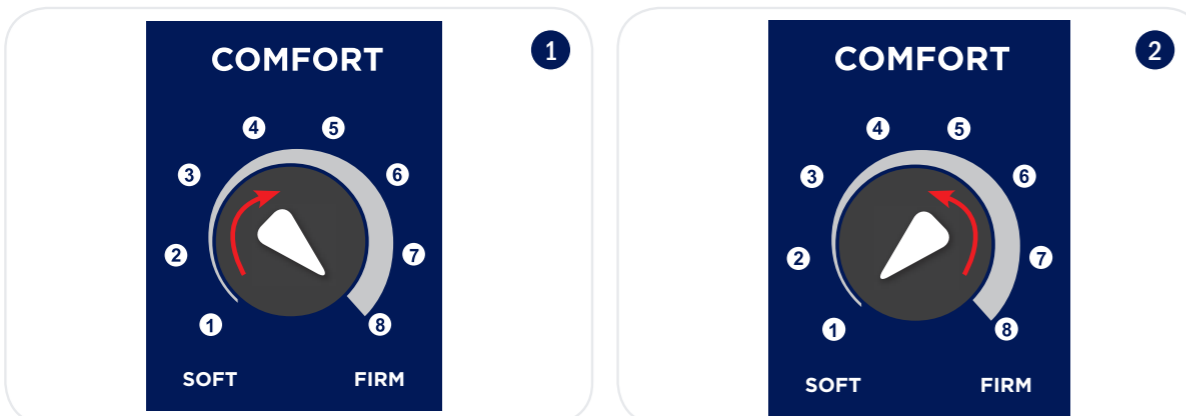

NOTE: It is imperative to ensure that the comfort level is set to the correct level dependent on the patients weight. The below table indicates the suggested pressure level according to the patient's weight:

Comfort Control	Patient Weight (KG)								
	30	40	50	60	70	85	100	115	135
1									
2									
3									
4									
5									
6									
7									
8									

Function Lock Out

Carers can lock out functions to ensure that functions are not accidentally toggled, impacting the operation of the overlay for the particular patient.

1. Press and hold the function lock out button until the LED light is illuminated. When illuminated the functions are locked out
2. To reverse this process, press and hold the function lock out button until the LED light is out. When LED is OFF all functions are unlocked



Mute

1. Press the mute button to nullify all alarms from the pump
2. If the issue is not rectified, the mute button will be automatically disabled and the alarm reactivated. This is a safety function to ensure a prompt response when an issue or fault occurs.



Low Pressure

To ensure correct pressure is achieved, the **'Low Pressure'** LED light will illuminate and an alarm will sound.

1. If the control pump senses low pressure, the Low Pressure LED light will illuminate and alarm
2. Refer to the troubleshooting sticker on the base of the pump to identify if there is a quick and easy solution, if not please contact your Aspire dealer immediately



Service Required

1. If the control pump senses a fault or issue, the service LED light will illuminate
2. Refer to the troubleshooting sticker on the base of the pump to identify if there is a quick and easy solution, if not please contact your Aspire dealer immediately



Power Failure

1. If the control pump senses a power failure, the **'Power Failure'** LED light will illuminate
2. Refer to the troubleshooting sticker on the base of the pump to identify if there is a quick and easy solution, if not please contact your Aspire dealer immediately



General Operation

CPR

1. Locate the CPR switch which is located at the **HEAD** end of the bed
2. Open the CPR valve by twisting the cylinder to the **RIGHT** to the **OPEN** position
3. Locate the hose connector connected to the pump at the **FOOT** end of the bed
4. Disconnect the hose connector from the pump

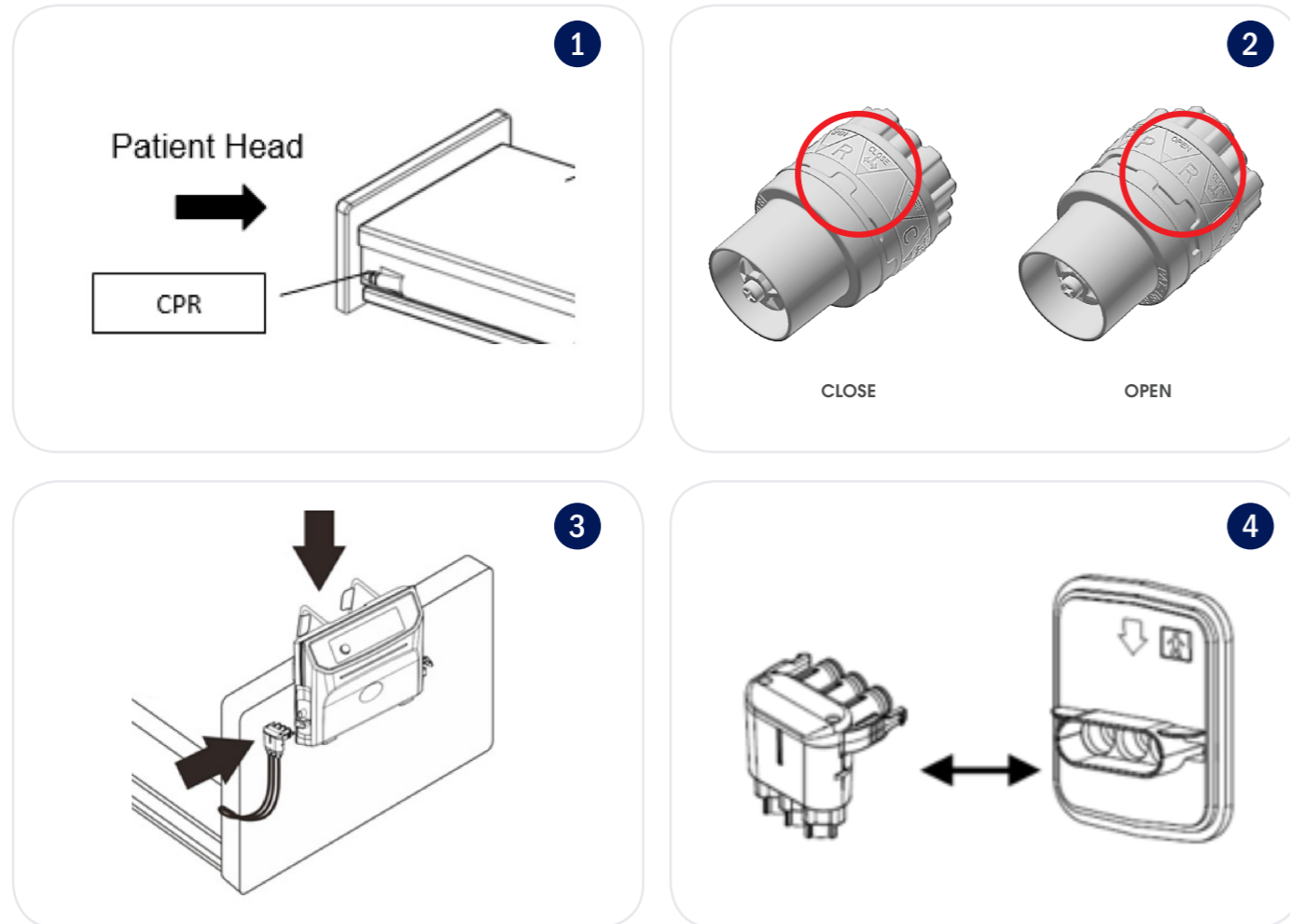

7. PRODUCT SPECIFICATIONS

PUMP UNIT	
Dimensions (mm)	330mm W x 220mm D x 120mm H
Weight (kg)	3.5kg
Cycle Times	10/15/20 minutes
Static Time	20 minutes
Pump Output Pressure Range (mmHg)	25 to 60 (±5)
Power	AC230 V 50Hz
Current	0.12 AMAX (@253V-)
Fuse Rating	T1AL 250VAC
Frequency	50 Hz (230V)
Classification	Class II
	Type BF
Operation Environment	5°C - 40°C
	15%RH - 93%RH (no condensation)
Storage Environment	-25°C - 70°
	93%RH (no condensation)
Environment Pressure	70 kPa-101.3kPa
Environment Horizontal Pressure	3000m
Water and Dust Protection Classification	IP21

AIR MATTRESS	
Dimensions (mm)	2000mm L x 850mm W x 100mm H
Weight (kg)	4.9kg
Cell Material	Nylon-TPU
No. of Air Cells	19
Cover Material	Multi-stretch PU coated fabric with high MVTR
Bottom Material	Polyester-PU
Max Weight	135kg

8. CLEANING

To ensure all infection control protocols are strictly adhered to, it is extremely important to follow the below steps to keep the Aspire Lifecomfort Active Air 4 clean at all times.

Mattress Pump

- Wipe with a damp cloth that has been pre-soaked with a mild detergent
- Ensure pump is kept free of dust and other particles



DO NOT! Immerse or soak the mattress pump at any time

Mattress Cover

- To remove small spills or stains, wipe the mattress cover with a damp cloth that has been pre-soaked with a mild detergent or single use disinfectant wipe
- To remove large spills or stains, the top cover should be completely removed and laundered as per below procedure:
 1. Remove top cover by unzipping all 4 x sides from the mattress base
 2. Prewash top cover at up to 95° for 15 minutes
 3. Main wash top cover at up to 95° for 15 minutes
 4. Dry mattress cover prior to use by hanging up on a line/air dryer or on a low heat setting it can be tumble dried for up to 90 minutes
 5. Once dry, reattach top cover by zipping all 4 sides back onto the mattress base



DO NOT! Use phenol based products



WARNING! After cleaning, the mattress must be completely dried prior to use



WARNING! Do not dry mattress cover in direct sunlight to prevent wearing out of text on cover

9. MAINTENANCE & STORAGE

To ensure longevity of your Aspire Lifecomfort Active Air 4 Mattress Overlay, it is very important that it is correctly stored and regularly maintained.

General

- Check mains power cable and plug for any abrasions or excessive wearing
- Check mattress cover for signs of wear or damage
- Check air hoses for any kinks or breakages

Fuse Replacement

- Disconnect the mains power if there is a blown fuse
- Remove the cover on the side casing of the pump
- Remove old fuse and reinsert a new fuse, fix in place with the cover



WARNING! Only use fuse supplied by your Aspire Dealer, ensuring it has the correct rating and specification

Air Filter Replacement

- Remove the cover on the rear casing of the pump
- Remove old filter and reinsert a new filter, fix in place with the cover

NOTE: If the filter does not require replacement, it can be cleaned by being washed gently with a mild detergent and warm water. Ensure the filter is dry prior to installing back into mattress pump.



WARNING! Only use filter supplied by your Aspire Dealer, ensuring it has the correct rating and specification

Storage

- Release all air from mattress by **OPENING CPR** valve and disconnecting mattress hose from pump
- Lay the mattress out flat & roll from **HEAD** end towards **FOOT** end
- Tighten mattress straps into clamps to prevent mattress unrolling
- Packing strap can then be stretched around the rolled mattress to prevent unrolling.
- Wrap power cord around the mattress

10. TROUBLESHOOTING

PROBLEM	SOLUTION
Pump will not connect with mattress	<ul style="list-style-type: none"> Check mattress and pump are compatible, only semi-digital Aspire pumps are to be used with this system Check plastic transport cap has been removed and ensure the connection is not broken If problem persists, contact your Aspire dealer
Pump not working	<ul style="list-style-type: none"> Check pump is connected to mains power Check power switch is in the ON position If problem persists, contact your Aspire dealer
Power failure	<ul style="list-style-type: none"> Check pump is connected to mains power Check power switch is in the ON position If problem persists, contact your Aspire dealer
Low pressure LED light flashing/alarm is going off	<ul style="list-style-type: none"> Check CPR valve is in CLOSED position Check air hoses/tubes are tightly secured Check all coupling connections along the mattress are secured If problem persists, contact your Aspire dealer
Pump is on but mattress will not alternate	<ul style="list-style-type: none"> Ensure mattress is inflated Check if ALTERNATING mode is ON Check if SERVICE REQUIRED LED is flashing, if yes, contact your Aspire dealer
Alarm is sounding	<ul style="list-style-type: none"> Press mute for system to be verified If alarm continues to sound, contact your Aspire dealer
Noisy pump operation	<ul style="list-style-type: none"> Check pump is mounted correctly and flat against FOOT end of the bed If noise persists, contact your Aspire dealer
Bottoming out but no alarm	<ul style="list-style-type: none"> Check pressure setting is correct for specific patient, adjust comfort dial according to patient weight range table on page 12 Refer to 'Low pressure light flashing/alarm is going off' point above If problem persists, contact your Aspire dealer

As a quick reference tool, refer to the troubleshooting sticker on the base of the pump casing for quick solutions. Always refer to the user manual where possible.



Warning Code	Action	Warning Code	Action
Power Failure	<ul style="list-style-type: none"> Check power cable is plugged into wall Check if power outage has occurred Check power switch is switched to on 	Low Pressure - Internal pressure below desired setting	<ul style="list-style-type: none"> Check mattress tubing is connected to pump Check CPR Valve is CLOSED Check cells are connected to manifold
Inflation Failure - Mattress not inflated after 60mins	<ul style="list-style-type: none"> Check mattress tubing is connected to PUMP Check CPR Valve is CLOSED 	System Failure	Press mute. If warning code does not stop then please contact your Aspire Dealer or Aidacare directly on 1300 133 120

If your problem persists, contact your Aspire Dealer or Aidacare directly on 1300 133 120

11. WARRANTY & SERVICE

Aspire Active Air 4 Alternating Mattress Overlays carry a comprehensive warranty as detailed below. Please keep proof of purchase for proof of warranty commencement.



Mattress Overlay



Pump

Consumer Warranty Against Defects:

Aidacare is bound by Australian Consumer Law in respect to Warranty Against Defects. A copy of the Aidacare Warranty Against Defects statement is available on the Aidacare homepage at www.aidacare.com.au. All warranty matters should be directed to Aidacare Customer Service on 1300 133 120.

Aidacare does not warrant against excessive or incorrect use, modification or any situation that could not be deemed as fair wear and tear. This is a back to base warranty and does not cover freight costs pertaining to the return of any items under warranty. Aidacare acknowledges and conforms to all ACCC guidelines around consumer rights. For further information contact Aidacare on 1300 133 120 or email product@aidacare.com.au.

Aidacare will not warrant the safety and or correct functioning of products where any original components have been changed or modified by non-Aidacare approved and trained service & maintenance staff or external providers. Furthermore, safety is not guaranteed where components have been replaced with non-original Aidacare approved parts. If any faults are detected upon receipt of this product please phone Aidacare. Any faults that are detected during normal use should be reported to Aidacare immediately to determine if warranty conditions apply and if so, the necessary repair or replacement work to be completed.

Spare parts list is available upon request.

For servicing, preventative maintenance and any other questions regarding this or any other Aidacare product please contact:

Aidacare Pty Ltd
 4 Noonan Rd, Ingleburn NSW 2565
 T - 1300 133 120
 W - www.aidacare.com.au
 E - product@aidacare.com.au

11. SERVICE LOG BOOK

YEAR 1 Date: _____

Service Type: _____

Condition Report: _____

Action taken: _____

Inspected By: _____

Signature: _____

YEAR 2 Date: _____

Service Type: _____

Condition Report: _____

Action taken: _____

Inspected By: _____

Signature: _____

YEAR 3 Date: _____

Service Type: _____

Condition Report: _____

Action taken: _____

Inspected By: _____

Signature: _____

YEAR 4 Date: _____

Service Type: _____

Condition Report: _____

Action taken: _____

Inspected By: _____

Signature: _____

YEAR 5 Date: _____

Service Type: _____

Condition Report: _____

Action taken: _____

Inspected By: _____

Signature: _____

YEAR 6 Date: _____

Service Type: _____

Condition Report: _____

Action taken: _____

Inspected By: _____

Signature: _____

YEAR 7 Date: _____

Service Type: _____

Condition Report: _____

Action taken: _____

Inspected By: _____

Signature: _____

YEAR 8 Date: _____

Service Type: _____

Condition Report: _____

Action taken: _____

Inspected By: _____

Signature: _____

YEAR 9 Date: _____

Service Type: _____

Condition Report: _____

Action taken: _____

Inspected By: _____

Signature: _____

YEAR 10 Date: _____

Service Type: _____

Condition Report: _____

Action taken: _____

Inspected By: _____

Signature: _____



Imported by:

AIDACARE P/L | 4 Noonan Rd, Ingleburn NSW 2565

T - 1300 133 120 | W - www.aidacare.com.au