

# Liko™ HygieneSling with SafetyBelt, Mod. 45

## Liko™ Hygiene SafetySling, Mod. 46

## Teddy Hygiene SafetySling, Mod. 46



### Instruction Guide



Mod. 45

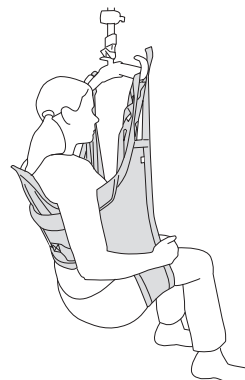

Mod. 46

## Product Description

This instruction guide is valid for Liko HygieneSling with SafetyBelt, Liko Hygiene SafetySling, and Teddy Hygiene SafetySling, but in the following text we will only use the name Liko HygieneSling.

Liko HygieneSling has been designed to facilitate dressing and undressing in connection with lifts to and from the lavatory. Caregivers often experience such lifting operations as heavy and difficult. With HygieneSling, dressing and undressing can be done during the actual lifting operation, thanks to the large opening around the seat of the sling.

Experience has shown that HygieneSling can work perfectly well for patients wearing long trousers or skirts and tights (pantyhose).

Liko HygieneSling is easy to apply, even if space around the wheelchair is very limited.

Liko HygieneSling is often the most appropriate alternative for patients with a certain degree of stiffness.

Liko HygieneSling in size XS is made of a Teddy bear patterned knitted polyester fabric and this is why this sling is called Teddy HygieneSling. In this size, the leg supports are reinforced and padded with a teddy bear patterned warp-knitted polyester fabric.

*In this document, the person being lifted is referred to as the “patient” and the person helping them is referred to as the “caregiver”.*

### Symbol description

 is a warning triangle used for situations which require extra care and attention.

 reference to read instruction guide for detailed information

Slings in sizes S to XL are made of green polyester and the leg supports are reinforced and padded with a curduroy fabric.

The patient should have relatively good torso and head stability to be able to sit comfortably and securely in HygieneSling. For patients with poor muscle tone, it is recommended to use a smaller size of HygieneSling or HygieneSling with SafetyBelt, Mod. 45 and 46.

For patients who tend to sink down in the sling, the safety belt distributes pressure and provides extra support during the lift. Model 46 is also equipped with an extra back support.

The HygieneSling can be used along with all of Liko’s overhead and mobile lifts. You can choose between the overhead lifts LikoGuard™, Likorall™, and Multirall™ or the mobile lifts Golvo™, Viking™, Uno™, and Liko™ M220/M230.

# Table of Contents

Safety Instructions .....	3-4
Care and Maintenance .....	4
Definitions .....	4
How to Attach a Sling to Different Sling Bars .....	5
How to Attach a HygieneSling to a Sling Bar with 4 Hooks (Twin Bars) .....	6
Lifting from Wheelchair to Toilet.....	7
Return from Toilet to Wheelchair .....	8
Advice for Trial Fitting.....	9-10
Different Ways of Connecting Leg Supports .....	9
Shortening Position .....	10
Description of SafetyBelt .....	10
Adapt the Length of the Strap to the Patient's Girth.....	11
Alternative Slings for Lifting to and from the Toilet .....	11
Overview, Liko™ HygieneSling Mod. 45, 46.....	12
Recommended combinations .....	12

# Safety Instructions

## Before lifting, keep the following points in mind:

- A responsible person within your organization should decide on a case-by-case basis whether one or more caregivers are needed.
- Ensure that the sling selected meets the patient's needs with reference to model, size, fabric and design.
- The total maximum load for a lift system is always determined by the product in the system with the lowest specified maximum load.
- For safety and hygiene reasons, use individual slings.
- Plan the lifting operation so that it can be done as safely and smoothly as possible.
- Check that the lifting accessory hangs vertically and can move freely.
- Although the Liko sling bars are equipped with latches, special caution must be exercised: before the patient is lifted from the underlying surface, but when the straps are fully extended, make sure the straps are correctly connected to the sling bar hooks.
- Make sure the patient is sitting securely in the sling before transferring to another location.
- Never lift a patient higher off the underlying surface than is needed to complete the lifting and transfer procedure.
- Do not use the handles to lift! Excessive force on the handles can cause the sling to tear.
- Never leave a patient unattended during a lifting situation.
- Make sure that the wheels on the wheelchair, bed, gurney, etc., are locked during the lifting/transfer operation.
- Always work ergonomically. Use the patient's ability to actively participate in the operations.
- When the sling is not being used, do not place in direct sun light.

## Medical Device Class I Product

Liko HygieneSling complies with the harmonized standard ISO10535:2006

The management system for both manufacturing and development of the product is certified in accordance with ISO9001 and its equivalent for the medical device industry, ISO13485. The management system is also certified in accordance with the environmental standard ISO14001.

### **PATENT [www.hill-rom.com/patents](http://www.hill-rom.com/patents)**

**May be covered by one or more patents. See above Internet address.**

The Hill-Rom companies are the proprietors of European, US, and other patents and pending patent applications.

### **Design and Quality by Liko in Sweden**

Liko's products undergo continuous development, which is why we reserve the right to make product changes without prior notice. Contact your Hill-Rom representative for advice and information about product upgrades.

### **IMPORTANT!**

Lifting and transferring a patient always involves a certain risk. Read the instruction guide for both the lift and lifting accessories before use. It is important to completely understand the contents of the instruction guide. The equipment should be used only by trained personnel. Ensure that the lifting accessories are suitable for the lift being used. Exercise care and caution during use. As a caregiver, you are always responsible for the patient's safety. You must be aware of the patient's ability to handle the lifting situation. Instruction guides can be downloaded, free of charge, at [www.liko.com](http://www.liko.com).

## Care and Maintenance

Check the sling before each use. Check the following points with regard to wear and damage:

- Fabric
- Straps
- Seams
- Suspension loops

⚠ Do not use damaged lifting accessories.

If anything is unclear, please contact the manufacturer or supplier.

**Washing Instructions:** Please see the sling's product label and the attached appendix "Care and Maintenance of Liko Slings".

## Expected Life Time

The product has an expected life time of 1-5 years during normal use. Expected life time varies depending on the fabric, use frequency, washing procedure, and weight carried.



## Periodic Inspection

The product must be inspected at least once every 6 months. More frequent inspections might be required if the product is used or washed more often than normal. See Liko's protocol for Periodic Inspection for the respective product.

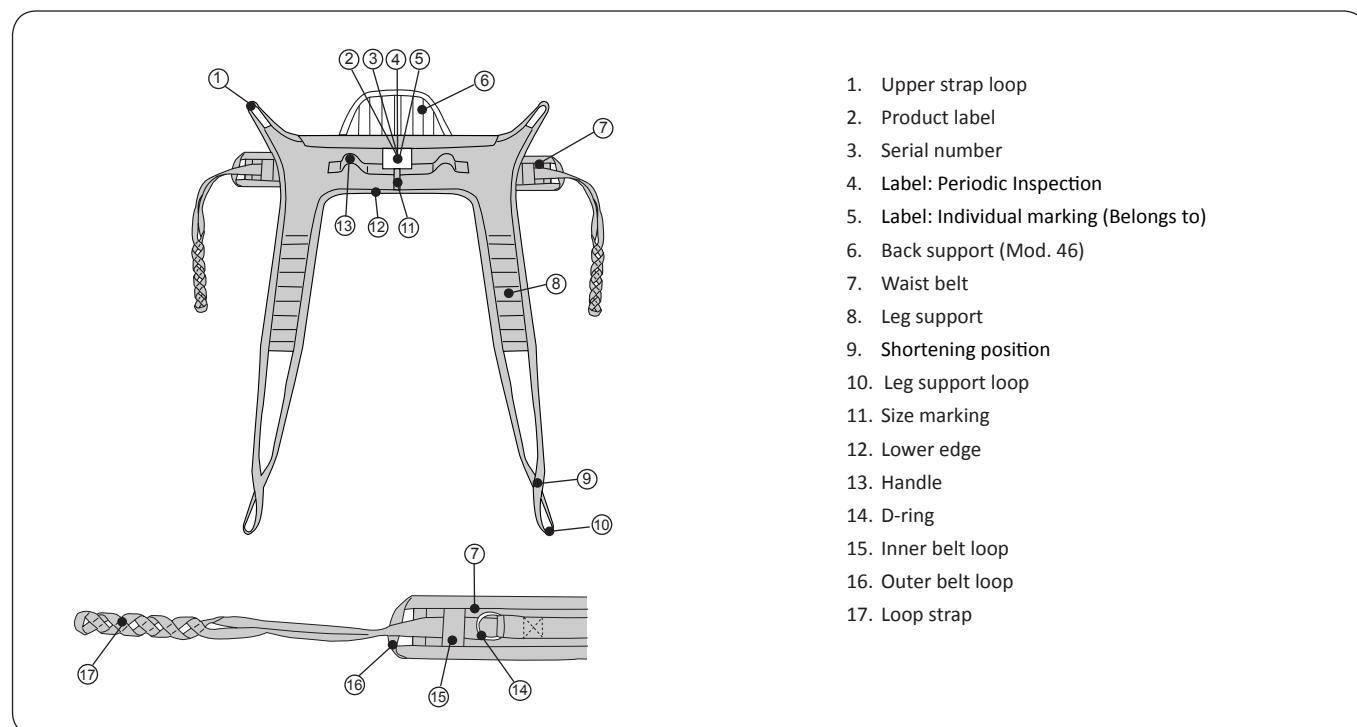
## Definitions

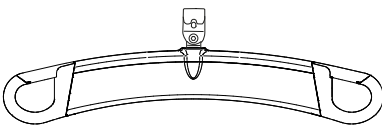
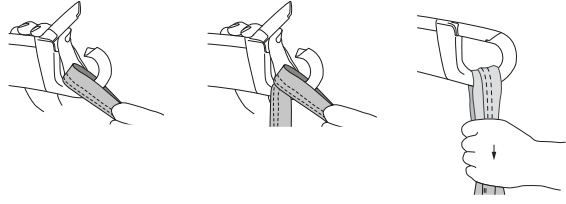
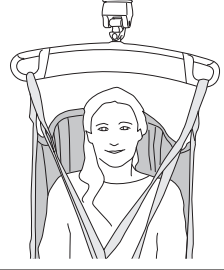
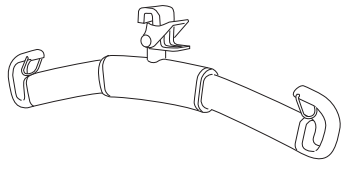
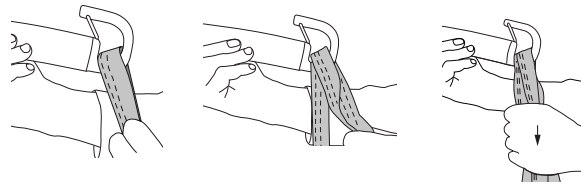

## How to Attach a Sling to Different Sling Bars

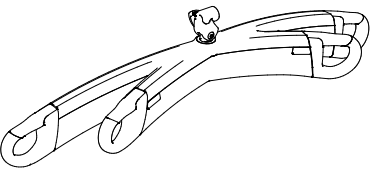
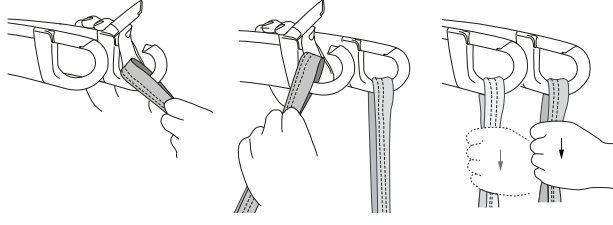
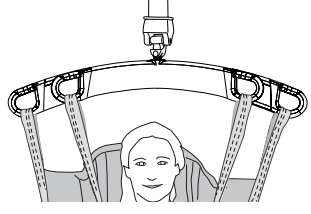
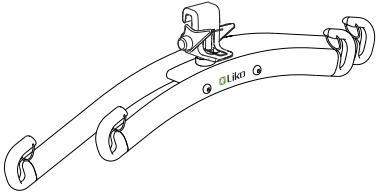
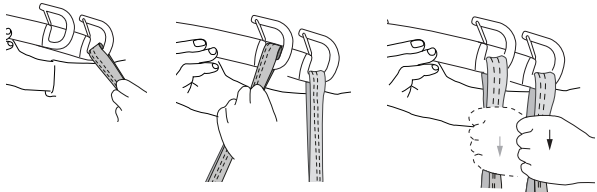
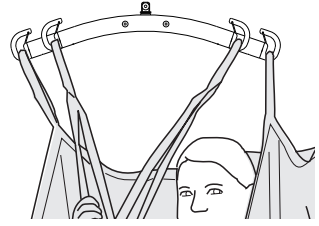
Sling bar	Sling loops to sling bar hooks	Correct
 <p>SlingGuard™</p>		
 <p>Universal</p>		
 <p>SlingGuard™ Twin</p>		
 <p>Universal Twin</p>		

### Wrong!

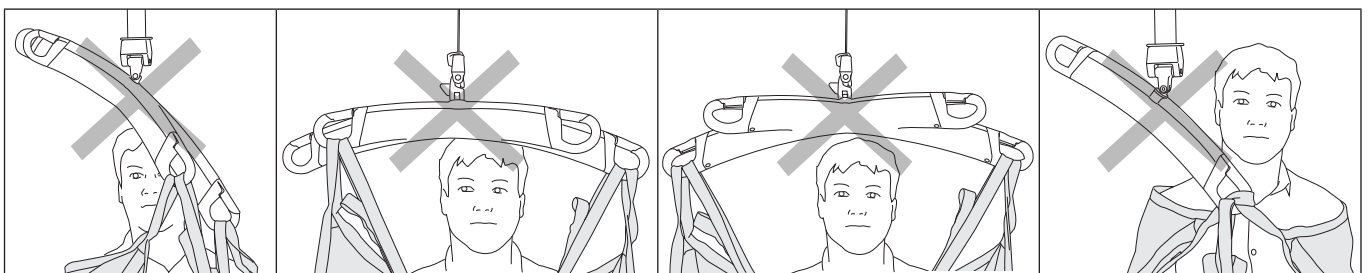

# How to Attach a HygieneSling to a Sling Bar with 4 Hooks (Twin Bars)

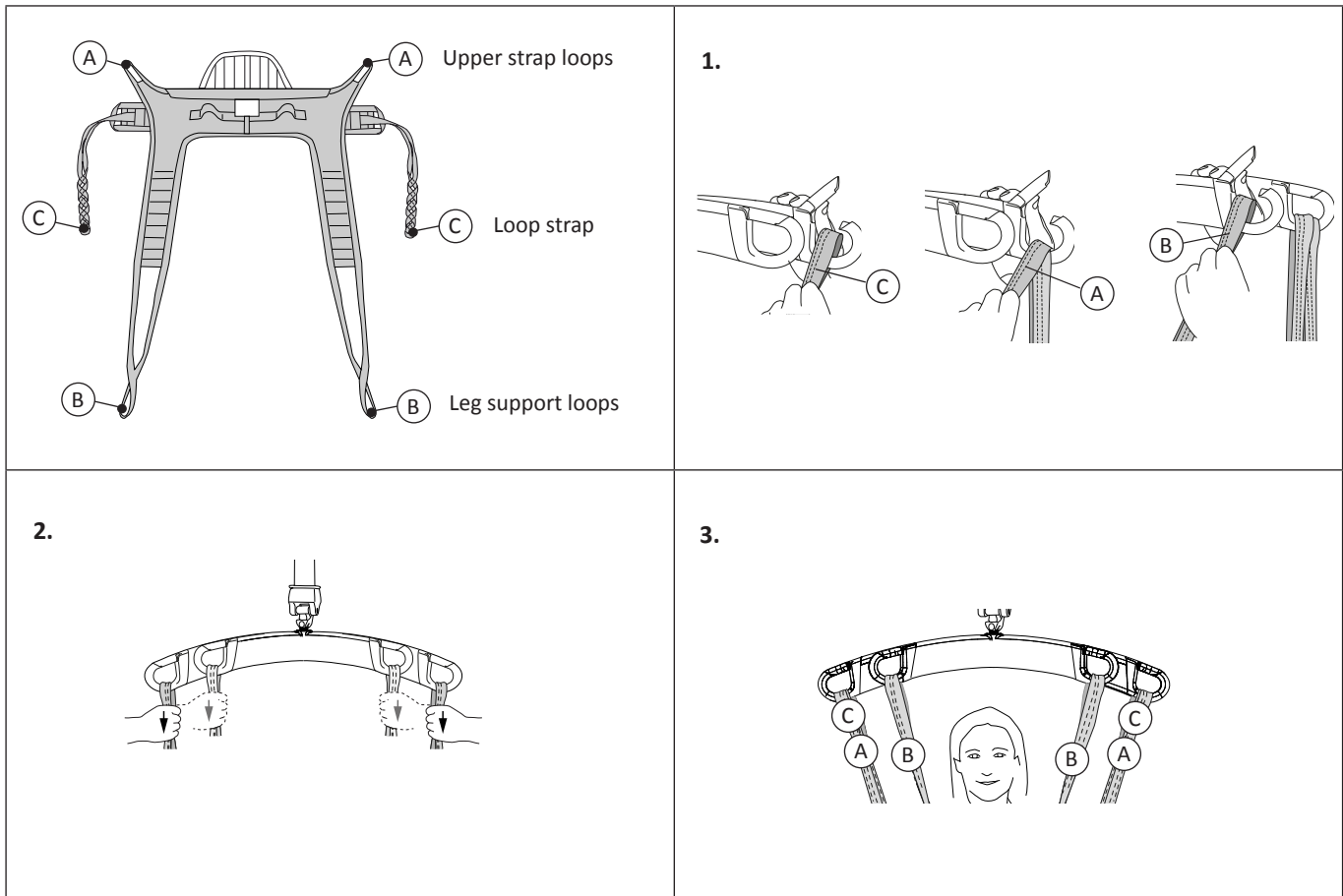

## Lifting from Wheelchair to Toilet

Study the description and instructions for safety belt and its adjustment first. Prepare to undress the patient by first undoing buttons and opening zippers.

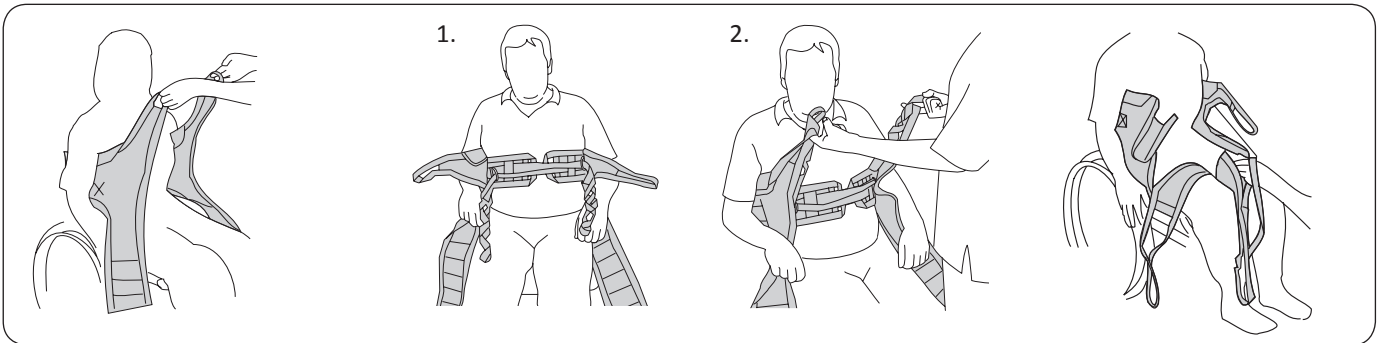

Place HygieneSling behind the patient, with the product label facing out about halfway down the back. The soft-padded upper edge should be just under the armpits.

1. Draw right loop strap through left D-ring. Draw left loop strap through right D-ring.  
2. Test the appropriate loops by pulling HygieneSling's upper strap loop and one of the loop strap's loops at the same time, as in the illustration above.

Place the leg supports under the patient's thighs. Cross the leg supports by drawing one leg support loop through the other.

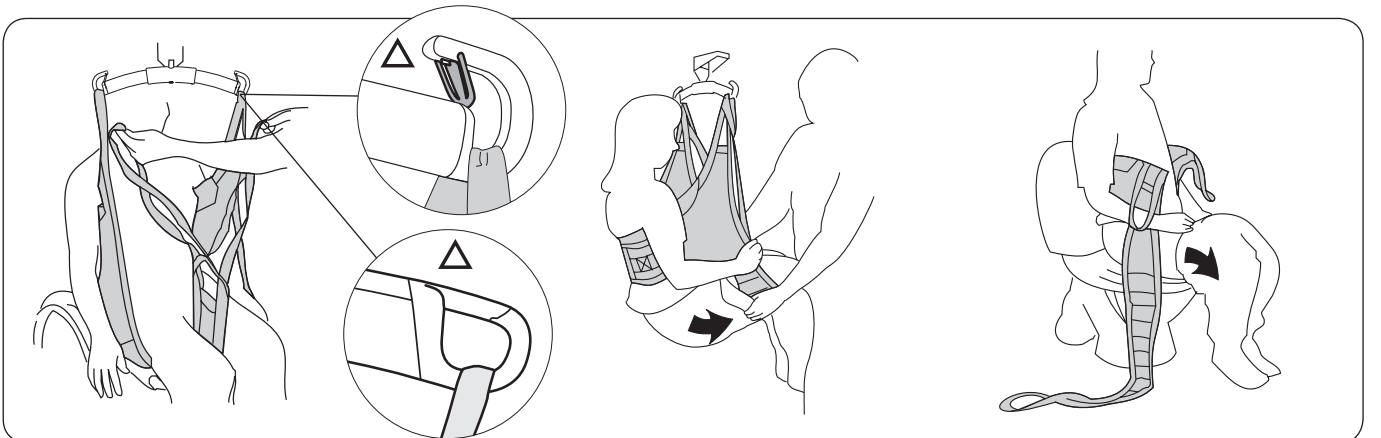

Move the sling bar forward and connect the loop straps first. Then connect the upper strap loops, and finally, the leg support loops. See page 5-6 for instructions on how to attach the sling loops to different sling bars.

Lift the patient. Pull the patient's pants down as far as possible.

Lower to the toilet. Move the leg supports aside and lower the patient's pants even further to enable better access.

## Return from Toilet to Wheelchair

Below, we describe two ways of dressing the patient after the visit to the toilet is concluded. The most appropriate alternative depends on the patient's physical condition and clothing.

**Alternative 1:** Leg supports outside trousers. This is appropriate with non-stretch trousers.

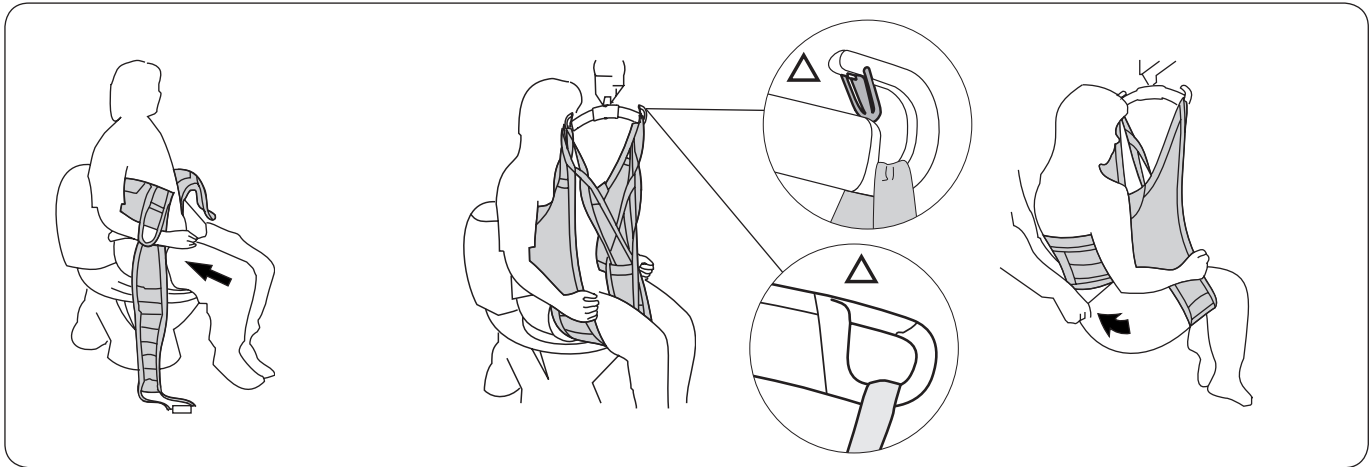

Pull the trousers up as far as possible towards the crotch.

Place the leg supports under the legs, but outside the trousers. Connect all the loops. See page 5-6 for instructions on how to attach the sling loops to different sling bars. Lift the patient.

If an incontinence pad is to be used, fit it in place before the trousers are pulled all the way up. Make the transfer and lower to the chair.

**Alternative 2:** Leg supports first – trousers outside. This method is suitable with stretch-fabric trousers.

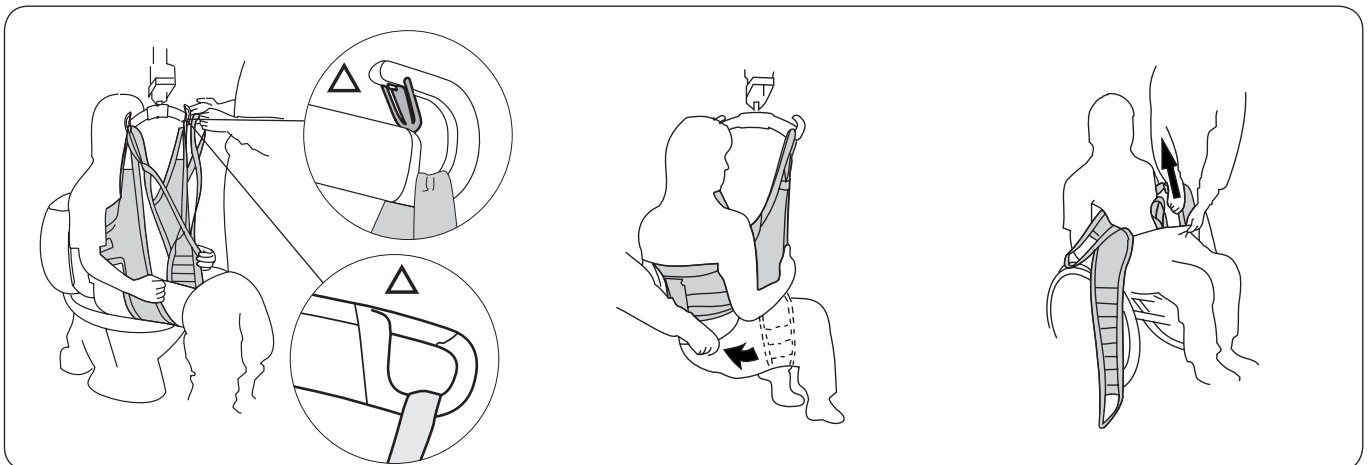

Apply HygieneSling according to the instructions on page 7. Connect all of the loops. See page 5-6 for instructions on how to attach the sling loops to different sling bars. Lift the patient. If an incontinence pad is to be used, fit it in place inside the crossed leg supports.

Pull the trousers right up over the seat and sling while the patient is still sitting in HygieneSling. Lower to the chair.

Disconnect the sling from the sling bar. Carefully work the leg supports out of the trousers and remove HygieneSling.



## Advice for Trial Fitting

△ The sitting position depends on where the leg supports are placed under the patient's legs. For someone with poor muscle tone, they should be placed high up toward the groin so that he/she does not sit too low in the sling.

Patients with poor muscle tone usually sit better in a smaller HygieneSling size. For users with high muscle tone, the opposite applies. They sit better in a larger HygieneSling, provided that the back support is placed high enough and the leg supports are close enough to the bends in the knees.

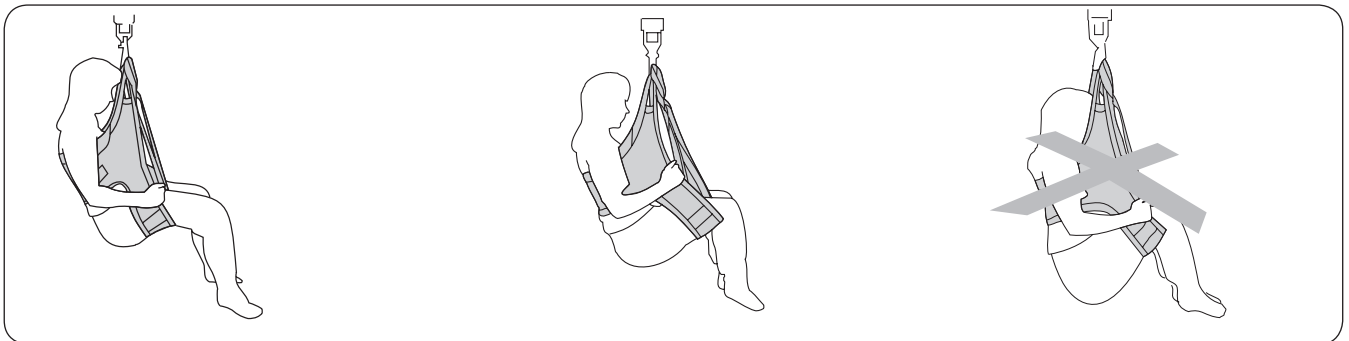

In most cases, and especially in the case of patients with weak musculature, the leg supports should be placed as close as possible to the crotch.

On a patient with good muscle tone, the leg supports can be placed closer to the knees. This makes dressing and undressing easier and helps to ease spasticity.

A sunken and uncomfortable sitting posture is either a result of the leg supports being placed too close to the knees and/or the sling being too large. Try a smaller size.

### Different Ways of Connecting Leg Supports

Before a connection alternative is chosen, an individual assessment should be performed to anticipate possible risks.

The following are general advice since the same principles are valid for several sling models.

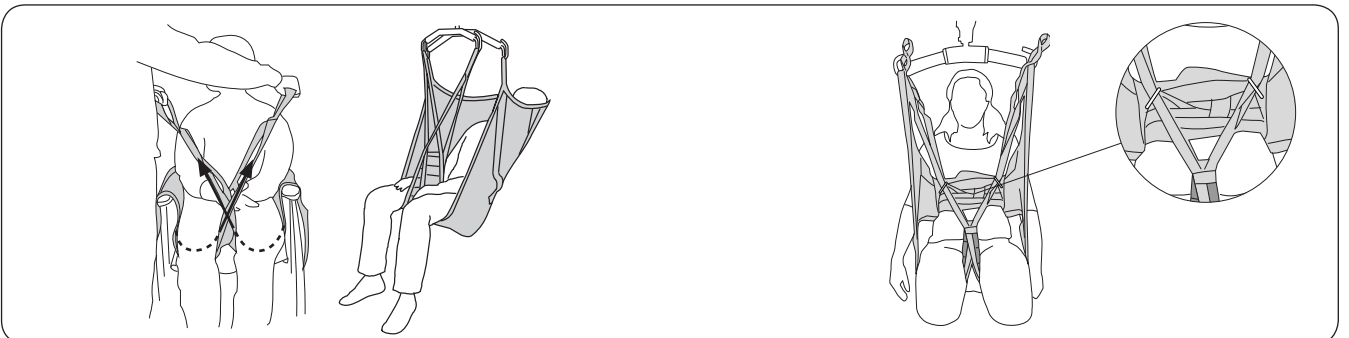

#### Crossed-over leg supports.

The most common way of applying the sling. One leg support loop is passed through the other before the loops are connected to the sling bar.

For some patients, e.g. amputees, it may be helpful to pull the leg support loops through the metal D-rings, before attaching them to the sling bar. This prevents the leg supports from sliding forward on the legs.

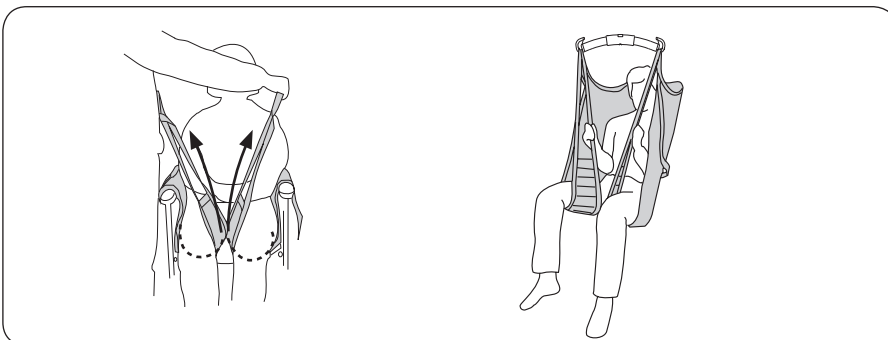

#### Each leg support connected separately to the sling bar.

This can be appropriate when lifting patients with particularly sensitive genitals.

△ Increased risk of sliding out.



## Shortening Position

In certain cases, it can be advantageous to shorten the leg support loop in order for the patient to sit well in the sling. The shortening position can be used temporarily in order to test for the right length, but extended use may damage the bartacks. If you want to shorten the leg support loop for long-term use, however, it is recommended that you tie a knot in the loop to shorten it about 10 cm (4 in). In this case, it is the outer leg support loop which should be connected to the sling bar.

## Description of SafetyBelt

The safety belt provides extra support for patients with poor muscle tone. The belt supports the upper body of the patient who tends to sink down in the sling during lifting.

However, the safety belt must not be so tightly fastened that it lifts the patient's body initially; i.e., the safety belt must not lift before HygieneSling's upper strap loops begin to lift. If this occurs, it may cause the patient to lean back inappropriately.

## Adjustment of Loop Straps

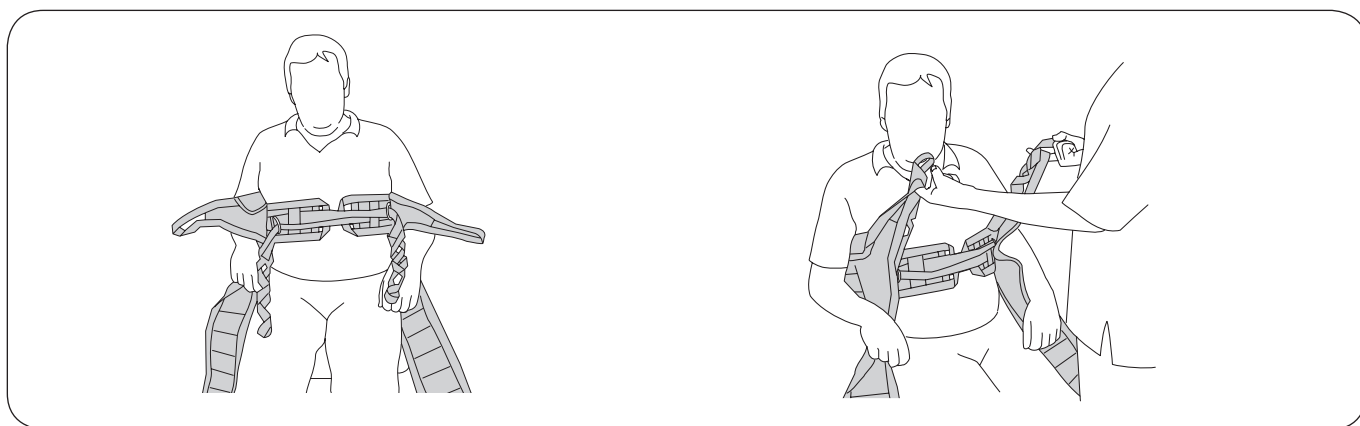

The loop straps must be crossed and pulled through the D-rings before the selected strap loop is hung on the sling bar.

The degree of tension applied by the loop straps around the upper body depends on which of these loops is hooked to the sling bar. By test lifting with different loops at the same time as HygieneSling's upper strap loops are used, you can determine which position gives the right tension. An inner loop gives more tension, while an outer loop reduces the tension.

**When correctly adjusted, the loop straps provide somewhat less tension than the HygieneSling's upper strap loops.**

## Loop Clips

This practical accessory is used to mark the loops that have been tried out for a certain person. It makes it easier for the caregivers to choose the right loop to attach to the sling bar.

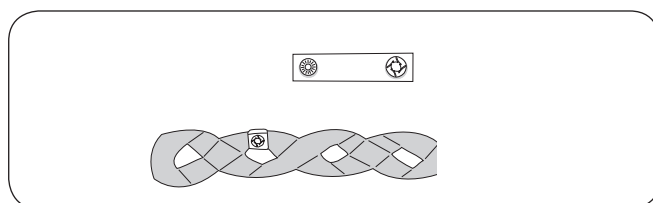

## Adapt the Length of the Strap to the Patient's Girth

If necessary, for optimal function, the length of the waist belt can be adapted to the girth of the patient.

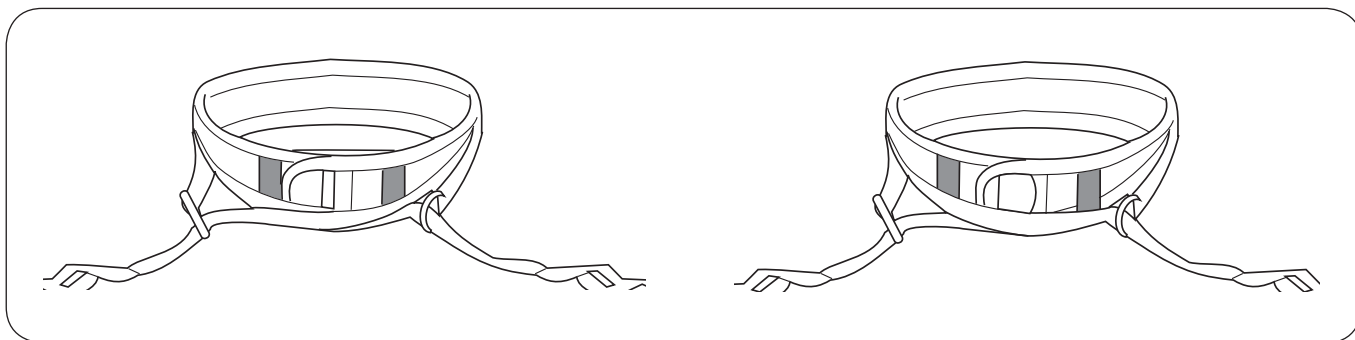

### Alt. A: For very thin patients

Pull the loop straps out of the inner belt loops before drawing them through the metal rings.

This enables maximum tension.

### Alt. B: Intermediate size

Pull only one loop strap out of the inner belt loop.

Cross the loop straps and draw them through the metal rings.

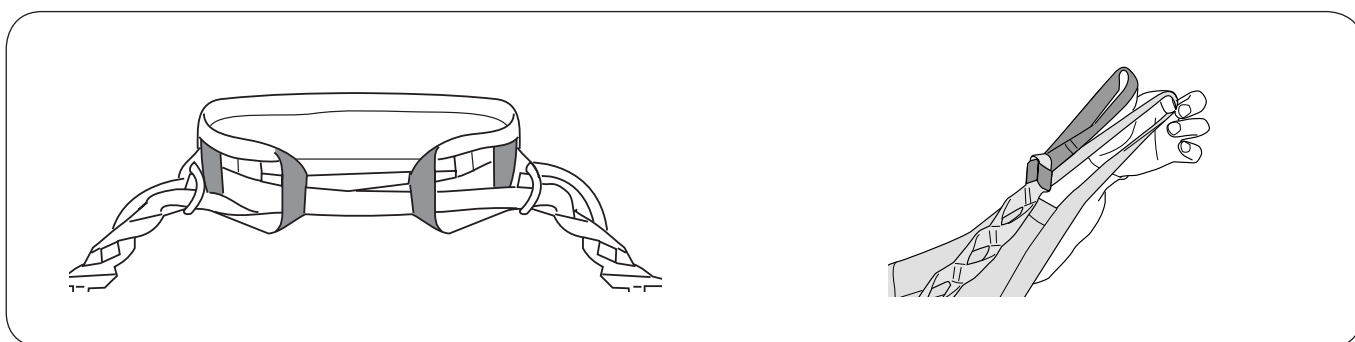

### Alt. C: For larger patients

Pass the loop straps through both the inner and outer belt loops before drawing them through the metal rings.

**Helpful hint:** To accommodate an even wider girth, the loop straps can be lengthened with Liko Extension Loops.

## Alternative Slings for Lifting to and from the Toilet

In our wide selection of slings, there are many models that can be used for toilet-related lifting situations. Please visit [www.liko.com](http://www.liko.com) for more information. Following is a sampling of possible alternative slings:

Liko HygieneSling, Mod. 40

Liko HygieneSling with Belt, Mod. 41

Liko HygieneVest™, Mod. 50

Liko HygieneVest™ High Back, Mod. 55

Liko OriginalSling, Mod. 10/11

Liko ComfortSling Plus with Hygiene Opening, Mod. 310

Liko ComfortSling Plus High with Hygiene Opening, Mod. 360

Liko MasterVest™, Mod. 60

Liko MasterVest™ front closure, Mod. 64

# Overview, Liko™ HygieneSling Mod. 45, 46

Product	Prod. No.	Prod. No.	Size	Patient weight <sup>1</sup>	Maximum load <sup>2</sup>
Teddy HygieneSling		3546813	XS	< 30 kg (66 lbs.)	200 kg (440 lbs.)
Liko HygieneSling	3545134	3546134	S	25-50 kg (55-110 lbs.)	200 kg (440 lbs.)
Liko HygieneSling	3545135	3546135	M	40-90 kg (88-198 lbs.)	200 kg (440 lbs.)
Liko HygieneSling	3545136	3546136	L	80-120 kg (176-264 lbs.)	200 kg (440 lbs.)
Liko HygieneSling		3545137	XL	100- kg (220- lbs.)	300 kg (660 lbs.)

<sup>1</sup> The indicated patient weight is a guideline only – there may be deviations.

<sup>2</sup> To maintain maximum load, lift/accessories intended for the same load or more are required.

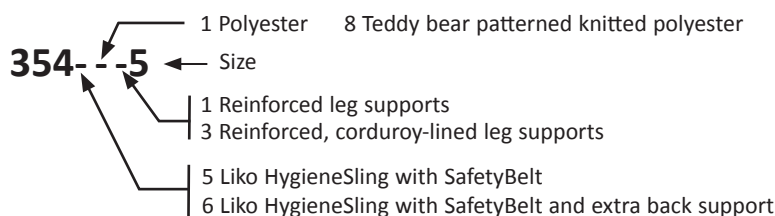

## Recommended Combinations

Recommended combinations with Liko HygieneSling and Liko's sling bars:

	Mini 220	Slim 350	Universal 350	Standard 450	Sling bars 450 <sup>1</sup>	Universal 600	Wide 670	Twin bars 670 <sup>2</sup>
Teddy HygieneSling, Mod 46, XS	1	1	1	2	2	3	4	4
Liko HygieneSling, Mod. 45/46, S	1	1	1	2	1	3	4	4
Liko HygieneSling, Mod. 45/46, M	1	1	1	1	1	3	3	3
Liko HygieneSling, Mod. 45/46, L	1	1	1	1	1	2	2	2
Liko HygieneSling, Mod. 45, XL	2	1	1	1	1	2	2	2

<sup>1</sup> Sling bars 450 relates to Universal SlingBar 450 Prod. No. 3156075, 3156085, and 3156095, and also SlingGuard 450 Prod. No. 3308020 and 3308520.

<sup>2</sup> Twin bars 670 relates to Universal TwinBar 670 Prod. No 3156077, and 3156087, and also SlingGuard 670 Twin Prod. No. 3308040 and 3308540.

Combinations with Liko Hygiene Sling and Cross-bar, Cross-bar 450/670 or SideBars is not appropriate.

**Explanation:** 1 = Recommended, 2 = May work, 3 = Not advised, 4 = Inappropriate

## Other Combinations

Combinations of accessories/products other than those recommended by Liko can result in risks for the safety of the patient.



www.hill-rom.com | www.liko.com